

EQB

THIS IS FOR
NEW DIMENSIONS.





This is for new dimensions.

Experience electric mobility in a new dimension: with up to seven seats, the all-electric space sensation adapts to your transport requirements. Comfortable, locally emission-free and virtually silent, it enables you to reach every destination relaxed and carefree.



Edgy and full of character on the outside.

The EQB is characterised by expressive lines that serve to emphasise its confident performance. The design of the all-electric compact SUV interprets the concept of progressive luxury in a way that is edgy and full of character. The black panel radiator grille with its central star, along with the distinctive LED light strip front and rear, flag up the EQB as a member of the Mercedes-EQ family. Blue highlights in the headlamps reinforce the electric-car look.



Innovative and functional on the inside.

The unique atmosphere created by the targeted use of highlights gives the car a futuristic feel: the Widescreen Cockpit, an impressively back-lit trim element and rosé gold-coloured decorative elements on the air vents, seats and the vehicle key embody the electric character. Aluminium-look tube elements create the robust look in the interior – they feature as handles in the doors, in the centre console and in the dashboard on the front-passenger side.

More room for electric mobility.

Totally in line with your needs: its spacious interior and up to three seat rows mean that the all-electric EQB offers room for up to seven people. With the individually folding seats in the rear the boot capacity can be extended to as much as 1710 litres, making the EQB a real space sensation.





Electric driving can be this simple.

The Remote and Navigation Services from Mercedes me connect* make electric driving convenient and efficient, by ensuring that charging stations in the immediate area or along a route, as well as the current range, are always in view. Navigation with Electric Intelligence automatically schedules charging stops for you at available – and wherever possible high-performance – charging stations along the way. With the Mercedes me App you also have access to charging settings and pre-entry climate control from outside the vehicle.

* A personal Mercedes me ID and agreement to the Terms of Use for the Mercedes me connect services are required to use the services. In addition, the particular vehicle must be paired with the user account. Upon expiry of the initial term, the services can be renewed for a fee, provided they are at that point still offered for the corresponding vehicle. Initial activation of the services is possible within 1 year of first registration or initial operation by the customer, whichever occurs first.



Perfect for you: the EQB with MBUX.

MBUX stands for Mercedes-Benz User Experience. In short: this is all about you. You can control all the functions intuitively via the large display with touchscreen – by touch, but also by using gestures or speech, with “Hey Mercedes”. In addition, the system is capable of learning, and continually adapts to suit the driver’s needs even better. Practical interfaces for telephony and digital media make Smartphone Integration a straightforward process and round off the special infotainment experience.



Turn your home into your own charging station.

Charge your EQB conveniently from home: with the Mercedes-Benz Wallbox Home you charge your vehicle with up to 11 kW and thus many times faster than at a conventional household socket, making for convenient and easy charging.



Many routes. One charging network.

With the EQB and Mercedes me Charge you gain access to one of the most extensive charging networks with public charging stations. If you're in a particular rush you can simply use one of the numerous IONITY fast charging stations while, with the optional premium service, you can even charge at a discounted price. The prerequisite for discounted charging with IONITY is an active Mercedes me Charge contract. In addition, with Green Charging, Mercedes-Benz ensures via high-quality certificates of origin that an equivalent amount of electricity from renewable energy sources is subsequently fed into the power grid for the charging processes via Mercedes me Charge.

* Use of the "Mercedes me Charge" service requires a separate charging process with a selected third-party provider that handles payment and billing of the charging processes. Use of Mercedes me services requires a personal Mercedes me ID and agreement to the Terms of Use for the Mercedes me connect services.

For your safety.
And that of your passengers.

The intelligent driving assistance systems in the EQB bring added safety: they think ahead, have an eye on what is happening in the traffic and can not only take the pressure off you in day-to-day life, but also provide effective support in hazardous situations. You yourself, your passengers and other road users can thus be protected as the situation requires – even once you have reached your destination, for example, via the exit warning function.



Worry-free electric motoring.

Relaxed mobility is ensured by services and warranties that have been specially designed for the electric vehicles from Mercedes-EQ. They are available from the time of the vehicle purchase and help to ensure that you can enjoy electric mobility with your EQB. Special guarantees such as the battery certificate with performance promise for up to eight years or up to 160,000 kilometres for the high-voltage battery ensure enduring driving pleasure.





Extended standard equipment.

The extended standard equipment with the Progressive design and equipment line enhances comfort with such features as a leather steering wheel, reversing camera and EASY-PACK tailgate.

STANDARD SPECIFICATION

Progressive design and equipment line
Reversing camera
Ambient lighting
EASY-PACK tailgate
Adaptive Highbeam Assist
Speed Limit Assist
Remote and Charging Services Plus
Load Compartment Package

Advanced Package.

With the Advanced Package you take your EQB up to the next level. In addition to the extended standard equipment, you receive two sharply brilliant 10.25-inch displays in the form of a Widescreen Cockpit. Further intelligent systems such as Blind Spot Assist significantly increase the ride comfort.

ADVANCED PACKAGE: HIGHLIGHTS

Widescreen Cockpit, consisting of media display and fully digital instrument display, each with 10.25-inch screen diagonal
Parking Package with reversing camera
Mirror Package
Blind Spot Assist

Advanced Plus Package.

On top of the content of the Advanced Package, the Advanced Plus Package offers further added comfort: the THERMOTRONIC automatic climate control ensures your preferred temperature in the interior. You can also charge your compatible smartphone wirelessly in the centre console.

ADVANCED PLUS PACKAGE: HIGHLIGHTS

THERMOTRONIC automatic climate control
KEYLESS-GO Convenience Package
Advanced Sound System
Wireless charging system for mobile devices
Widescreen Cockpit, consisting of media display and fully digital instrument display, each with 10.25-inch screen diagonal
Parking Package with reversing camera

Premium Package.

The Premium Package offers top-level equipment and ensures exceptional ride comfort. It supplements all the previous equipment packages with additional highlights such as the Burmester® surround sound system and the panoramic sliding sunroof.

PREMIUM PACKAGE: HIGHLIGHTS

Parking Package with 360° camera
Burmester® surround sound system*
THERMOTRONIC automatic climate control
KEYLESS-GO Convenience Package
Wireless charging system for mobile devices
Widescreen Cockpit, consisting of media display and fully digital instrument display, each with 10.25-inch screen diagonal

* Temporarily unavailable due to supply shortages. In all likelihood available in the fourth quarter of 2022.



The Progressive design and equipment line.

Its design is as progressive as its claim. In the standard specification the Progressive design and equipment line adds exclusive highlights at no extra cost: with luxury seats in ARTICO man-made leather and Fléron fabric, including Seat Comfort Package, or the leather steering wheel. Features such as roof rails in polished aluminium ensure that the exterior really stands out.

EXTERIOR HIGHLIGHTS

Roof rails in polished aluminium

45.7 cm (18-inch) 5-spoke light-alloy wheels

Front and rear apron with chrome insert

Shoulderline and windowline trim elements in polished aluminium

INTERIOR HIGHLIGHTS

Luxury seats including Seat Comfort Package

Upholstery in ARTICO man-made leather, black Fléron fabric with mid-grey double topstitching

Multifunction sports steering wheel in leather with black topstitching and 2-part chromed trim

Air vents in silver chrome with outer ring in silver chrome and air guide ring in high-gloss black

Side trim panels in grained black with chromed insert

The AMG Line.

Confidently shows what it's made of: the EQB with AMG Line. On the outside, features such as the AMG-specific front apron and the AMG-specific black panel radiator grille reinforce the sense of strong forward thrust. On the inside the sports seats and the multifunction sports steering wheel make it clear that standing still is not an option.

EXTERIOR HIGHLIGHTS

AMG-specific front apron with trim elements in chrome plus functional AIR CURTAINS

AMG-specific black panel radiator grille in twin-blade design and with surround in high-gloss black

AMG rear apron in diffuser look with trim element in chrome

45.7 cm (18-inch) AMG 5-twin-spoke light-alloy wheels, aerodynamically optimised, painted in high-gloss black with a high-sheen finish

Side trim panels in grained black with chromed insert

INTERIOR HIGHLIGHTS

Sports seats with adjustable head restraint including Seat Comfort Package

Upholstery in black ARTICO man-made leather/DINAMICA microfibre with red double topstitching

3-spoke multifunction sports steering wheel in nappa leather, with flattened bottom section, with perforation in the grip area and Touch Control buttons

AMG pedals in brushed stainless steel with rubber studs

Air vents in silver chrome with outer ring in silver chrome and air guide ring in high-gloss black



Electric Art.

Masterfully showcasing electric mobility: the Electric Art interior. Colour highlights in contemporary rosé gold in the air vents and the upholstery, which consists partially of recycled materials, ensure a unique aesthetic in the vehicle interior. The back-lit trim element creates a futuristic ambience.

INTERIOR HIGHLIGHTS

Upholstery in ARTICO man-made leather/Cupertino fabric in two-tone rosé gold/titanium grey pearl

Spiral-look trim element, back-lit

Air vents in rosé gold with outer ring in silver chrome and air guide ring in high-gloss grey

3-spoke multifunction sports steering wheel in nappa leather, with flattened bottom section, with perforation in the grip area and Touch Control buttons

Door sills with illuminated, model series-specific lettering in blue

1 vehicle key in black with ornamental surround in chrome and 1 vehicle key with ornamental surround in rosé gold

Edition 1.

The unique Edition 1, available for a limited period, combines elements of the Night Package with elements of AMG bodystyling. The exterior has a sporty look with AMG-specific equipment features. In the vehicle interior the back-lit trim element and blue topstitching in seats and doors add clear highlights.

EXTERIOR HIGHLIGHTS

AMG-specific front apron with trim elements in chrome plus functional AIR CURTAINS

AMG-specific black panel radiator grille in twin-blade design and with surround in high-gloss black

AMG-specific rear apron in a diffuser look with trim element in chrome

50.8 cm (20-inch) AMG multi-spoke light-alloy wheels, aerodynamically optimised, painted matt copper with a high-sheen finish

INTERIOR HIGHLIGHTS

Upholstery in neva grey leather with CYBER CUT blue

Armrest in black ARTICO man-made leather with blue topstitching

Widescreen Cockpit, consisting of media display and fully digital instrument display, each with 10.25-inch screen diagonal

3-spoke multifunction sports steering wheel in nappa leather, with flattened bottom section, with perforation in the grip area and Touch Control buttons

Spiral-look trim element, back-lit



Electric drivetrain.

Efficiently electric: the drive technology of the EQB offers impressive power delivery for added efficiency, safety, comfort and driving pleasure – hallmark Mercedes-EQ, in fact. Two electric drivetrains (eATS) are used on the all-wheel drive models of the EQB: one at the front axle with an asynchronous motor and one at the rear axle with a permanently excited synchronous unit. From there they deliver a system output of up to **215 kW**¹ onto the road. The full torque is already available with the first touch of the accelerator pedal, without the slightest sense of hesitation during acceleration. Furthermore the EQB with DYNAMIC SELECT supports you through various drive programs with different characteristics – from efficient to sporty, for more driving pleasure in bends and comfort on long journeys.

¹EQB 250 | WLTP: combined electric energy consumption: **XXX-XXX** kWh/100 km; combined CO₂ emissions: 0 g/100 km.

The range has been determined on the basis of Commission Regulation (EU) 2017/1151. The range will depend on the vehicle configuration.

Driving Assistance Package.

The Driving Assistance Package sets new standards where safety and ride comfort are concerned: cameras, radar and ultrasound monitor the surroundings and provide situation-appropriate support for speed adjustment, steering and when there is the danger of a collision. To supplement this, various data from maps, navigation system and Live Traffic Information are used to assess routes and traffic in real time. The intelligent networking of all this information ensures tangible stress relief and optimum protection for you, your passengers and other road users during the journey.

Dimensions.

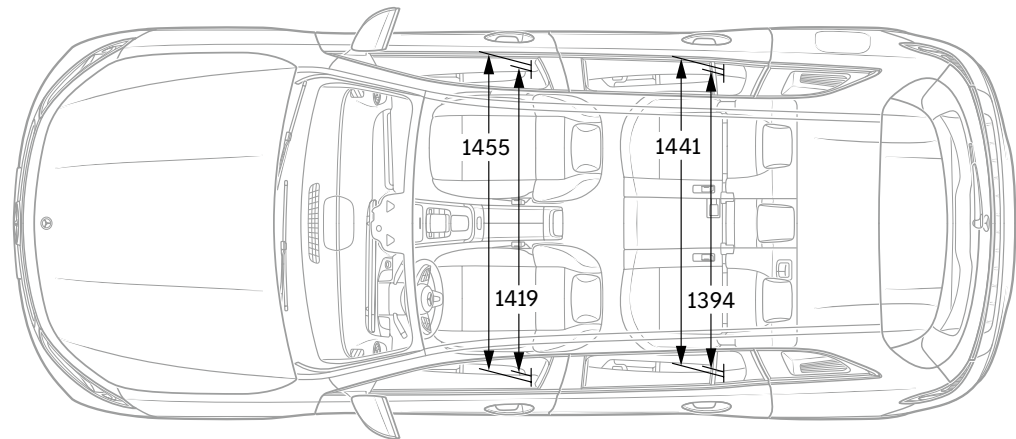
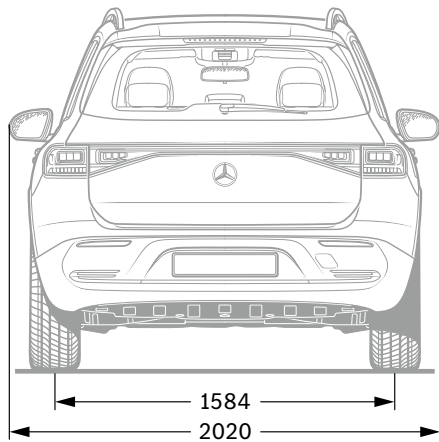
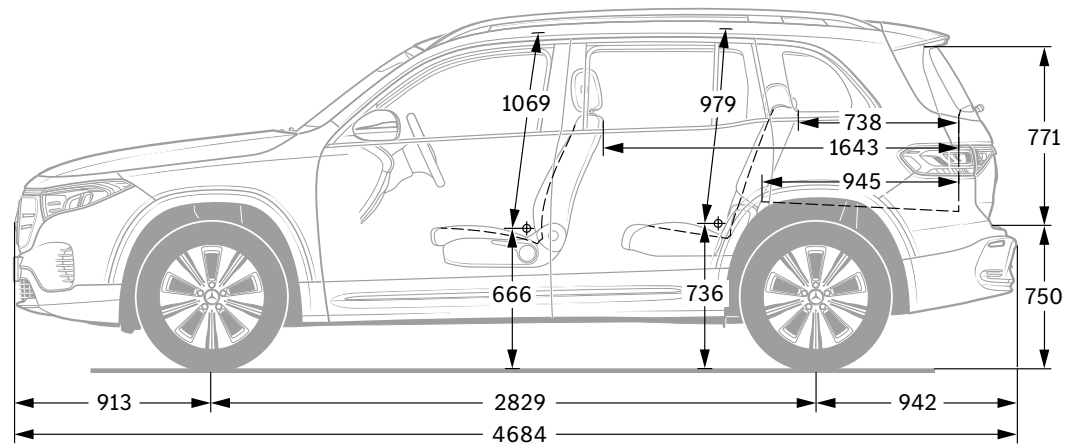
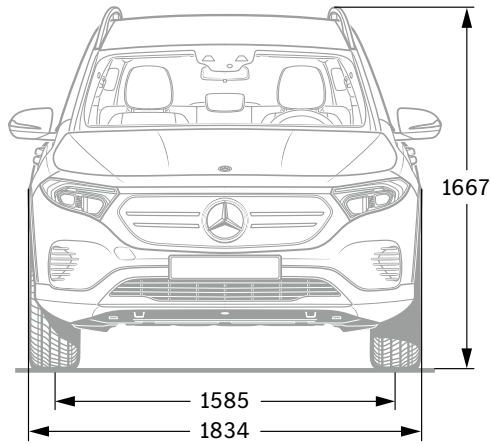

All figures in millimetres. The dimensions shown are mean values. They are valid for vehicles with standard equipment and in unladen condition.